

Technical Data

Wire Wound Pot

W-w Potentiometer uses a resistive element which looped copper nickel or nickel chrome resistive wire evenly around the cable core or card core.

Combination of the resistive element and a noble metal alloy wiper maintains the precision and steady performance.

Features

1. Low Temperature Coefficient of Resistance

Less than $\pm 20\text{ppm/K}$

2. A Great Resistance Design Freedom

Depending on the pitch of coil and diameter of the resistive wire, it is feasible to set the resistance value from a few ohms to a few hundred ohms.

3. Low Contact Resistance

Comparing to other resistive elements, contact resistance is low.

4. Center Tap

It is feasible to add center tap anywhere that you need within the total electrical travel.

Principle

Sliding Method

Sliding method of wire wound potentiometer is different depending on the number of turns and the type of resistive wire.

1. Low Temperature Coefficient

Resistive Part: Coiled resistive wire and alloy spring plate or hog-backed metal plate as a sliding wiper.

Corrector Part: Combination of a noble metal alloy spring ring and a collector spring.

2. Multi-Turn

Resistive Part: A helicoidal coiled resistive wire.



Technical Data

Mounting Instruction

Mounting Method

(1) Bushing Mount (Mounting Method A)

- Insert threaded part of pot through from the back side of mounting board and fasten the pot by a nut with washer.
- Be sure to place a washer behind of the nut.
- As for the pot with a stopper pin, make a hole for a stopper pin on a mounting board.
- Do not rotate the pot itself when tightening the nut. This may cause malfunction of the sensor.
- Do not over tighten the nut. This may damage the threaded part of the pot.

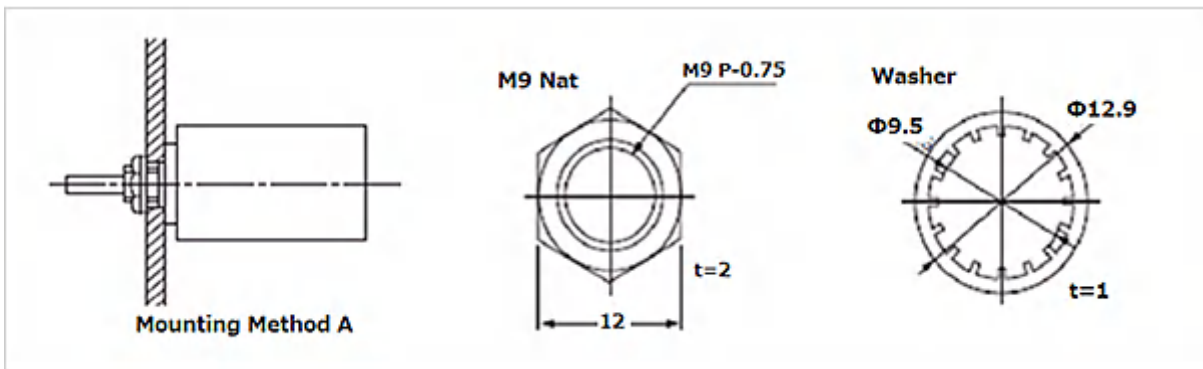

(2) Screw Mount (Mounting Method B1 and B2)

- Fasten the pot with screws into the tapped holes which is on the mounting surface of the Pot.
- Please use certain length of screw.
- In case of selecting mounting method 'B1', create a shaft hole on the mounting board which diameter is larger than the pot shaft diameter.

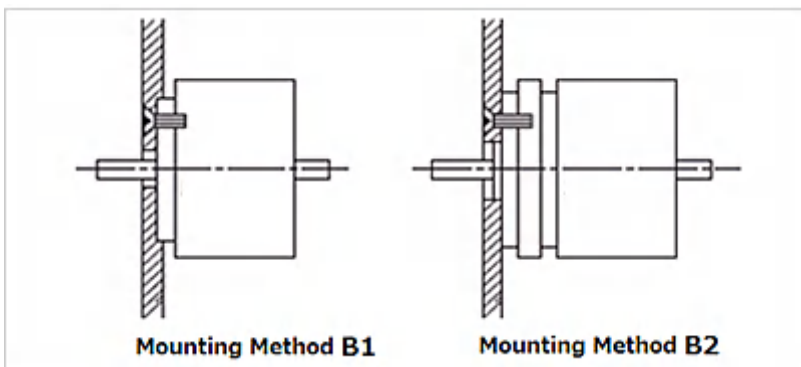

Technical Data

(3) Servo Mount (Mounting Method C1 and C2)

- Install a pot on the mounting board using mounting cleats.
- Make hole to fit diameter of matching flange.
- Do not tighten the screws for the mounting cleats until pot body is fixed at the desired position.
- Gears or couplings on the shaft smaller than diameter of mounting hole may be more convenient for installation.
- In case of using mounting method 'C1', place a few mounting cleats equally spaced by mounting hole.
- If there is no space to place the mounting cleats, it is recommended to use mounting method 'C2'.

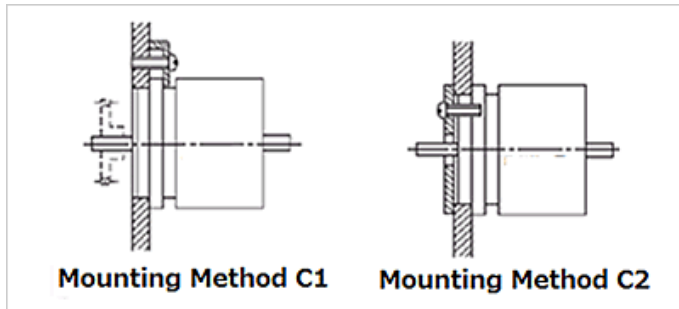

① CP-2F	
② Abolishment	
③ CPP-35 CPP-35B	
④ CP-45H CPP-45 CPP-45B CPP-5S	
⑤ CPP-60	

Technical Data

Effects of Loading

If finite load resistance is loaded on sensor output, linearity will become distorted as expressed in the following equation.

$$E_{\max} = \frac{14.8}{\frac{RL}{RP} + 0.22} (\%)$$

E_{\max} : Maximum linearity distortion caused by load resistance

RP : Total Resistance of Potentiometer

RL : Load Resistance

Show above equation in a graphic form, as shown right:

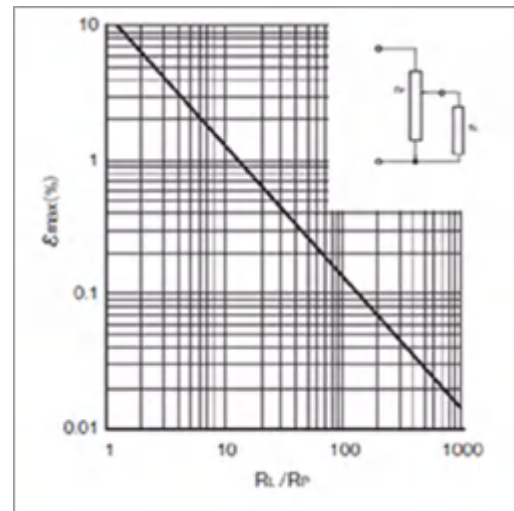

JEITA (Japan Electronics and Information Technology Industries Association) recommends that the added load resistance should be more than 100 times of the total resistance.

The higher the load resistance, the less effect of electrical noise on the output of the potentiometer. It is also effective in increasing the durability of the Green Pot.

Reducing Power

It is necessary to decrease the rated dissipation by the condition of the (1) Operating Temperature, (2) Load Resistance, (3) (4) Specifications to avoid damaging resistive element.

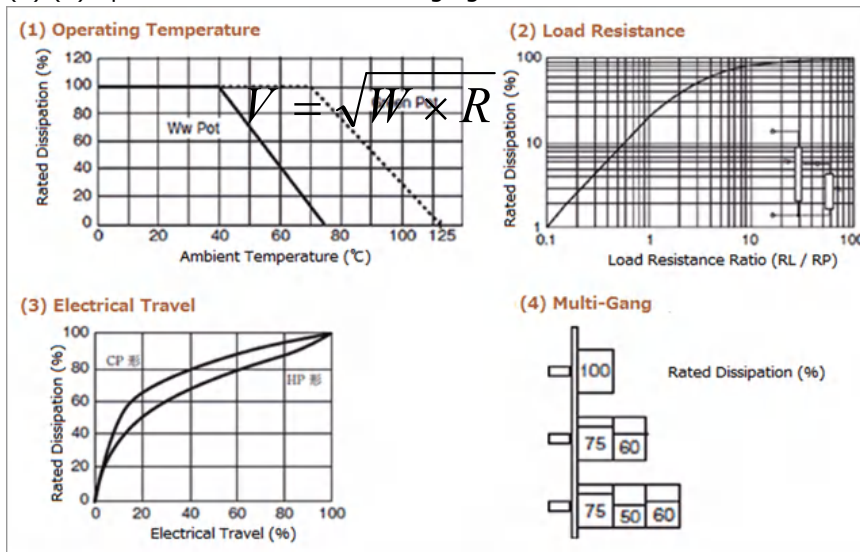

Input Voltage

Maximum input voltage (V) defined by the rated dissipation can be calculated by using the following formula.

$$V = \sqrt{W \times R}$$

V: Maximum Input Voltage

R: Total Resistance - Total Resistance Tolerance

W: Rated Dissipation

Shorted Segment

It is an area of the resistive element where the area has fixed output voltage ratio. The area is not included in the total effective electrical travel.

Technical Data

The Difference between Shorted Segment and Extra Segment

Depending on the process of resistive element, extra segments might be added out side of the total electrical angle. Voltage output characteristics of short segment and extra segment are both the same but in reading resistance value, there is difference as shown in the below charts. In extra segment, it is necessary to place terminals at the designated angle.

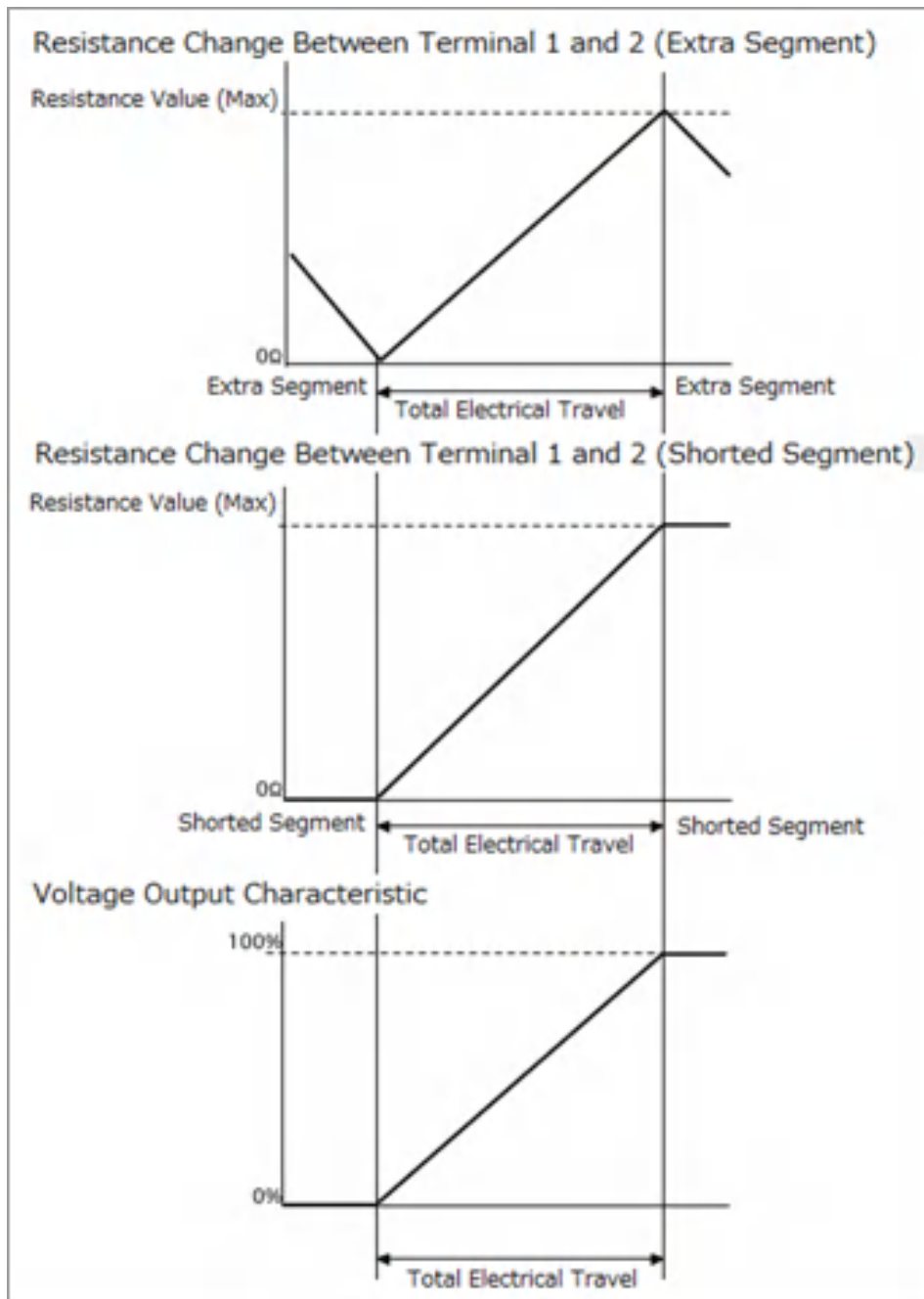

Technical Data

Operating Suggestions

If Green Pot is used in an environment with vibration or dither operation, resistive element may become partially worn by a sliding wiper causing shorter lifetime of the Green Pot.

Contactless sensor such as Blue Pot and Orange Pot are more suitable for those kinds of operating environment.

Burnout of Resistive Element

1. Wiring

Potentiometer is used for obtaining output voltage ratio from input voltage. Therefore, apply DC voltage (V_{in}) and read out the voltage (V_{out}) between output terminal and GND. Do not use potentiometer as a variable resistor.

2. Load Resistance

We recommend to add load resistance that is more than 100 times of the total resistance value. If added load resistance is low, current flow at power-supply line (Terminal 1 to 3 or lead wire black to red) will flow to the output line (Terminal 1 to 2 or lead wire white to red) and may cause burnout of resistive element when wiper at low-value resistance position. To avoid burn-out the resistive element, set wiper current lower than 1mA.

3. Miswiring

If output terminal (or output lead wire) is connected to power-supply line, it will increase the chance of burning out the resistive element.

4. Multimeter

When checking total resistance or measuring resistance value of Green Pot by analog multimeter, increase the range of the analog multimeter to make the needle move widely and higher current flow may be generated. Please use analog multimeter with lower range than 1mA or we recommend to use the digital multimeter.

5. Over Rated Dissipation

If over voltage such as surge is supplied to potentiometer, it will cause burnout of the resistive element.

Technical Data

Handling Instruction

Potentiometers are precisely assembled and adjusted. Please handle them carefully as a precision device.

1.

- Do not disassembling the pot.
 - Do not modify the Pot
- (May effect the precision and cause malfunction.)

2.

- Do not drop the Pot.
 - Do not strike one part against another
- (May damage the terminals or cause wires to disconnect.)

3.

- Do not apply excessive voltage or current.
- (May damage resistive element an electronic Components.)
- make sure to use digital tester.
- (may damage resistive element and electronic components if analog tester is used.)

4.

- Mount without tapping or squeezing into a panel.
 - Use suitable tools
- (May break or cause failure.)

5.

- Use wire that has sufficient length for connection terminals.
 - Use wire less than 0.3mm² (AWG22) in cross section.
- (Insufficient length of wire or use of larger wire may cause damage to the terminals or disconnection inside the pot.)

6.

- Be sure to connect appropriately.
 - Do not apply voltage on output terminals.
- (May damage resistive element and electronic components.)

7.

- Solder no more than 5 seconds at 300°C MAX.
- (High temperature may damage inside of pot.)

8.

- Do not apply excessive torque to the mechanical stopper of rotary type pot.
- (may cause breakage of stopper. Stopper strength: 0.3-0.5N.m MAX. typical)

9.

- Do not immerse in water or pour water or chemicals on the pot.
- (may cause output failure)

Technical Data

10.

•Observe precautions for handling electrostatic discharge sensitive devices.
(Orange Pot is using the electrostatic discharge sensitive semiconductor circuits.)

11.

Do not store pot in the following conditions.

- High humidity
- Dusty environment
- Place where salinity or corrosive gases are present.
- Vibrating place

Units

The units in the web site is the International System of Units (SI).

Torque	$1\text{kgf}\cdot\text{m} = 9.80655\text{N}\cdot\text{m}$, $1\text{N}\cdot\text{m} = 0.10197\text{kgf}\cdot\text{m} = 101.97\text{gf}\cdot\text{m}$
Force	$1\text{kgf} = 9.80655\text{N}$, $100\text{gf} = 980.655\text{mN}$, $1\text{N} = 0.10197\text{kgf} = 101.97\text{gf}$, $5\text{N} = \text{approx.}500\text{gf}$
Acceleration	$1\text{G} = 9.80655\text{m/s}^2$, $150\text{m/s}^2 = \text{approx.} 15\text{G}$, $500\text{m/s}^2 = \text{approx.} 51\text{G}$
Magnetic Flux Density	$1\text{G} = 1 \times 10^{-4} \text{ T}$

In addition to the Handling Instructions in this web site, please read the following guidelines with a good understanding of its contents:

- Manufacturing date indication (JEITA RC-0901)
- Precautions of potentiometer (JEITA RCR-2191A)
- Safety Application Guide on Components for Electric Devices and Electric Manufactures (JEITA RCR-1001B)

Guaranty

1. If our products are intended to be used for any applications that required high reliability such as nuclear power, satellite, and medical devices, please contact us before purchasing.
2. Environmental specifications that are indicated on this web catalog are guaranteed based on the test conditions established by our company. It is not guaranteed the performance in actual use. When making a decision to adopt our products, please be sure to examine the products by mounting and testing them beforehand at your own risk.
3. Although specifications and handling instructions of each products were offered in this web catalog, the function may be limited depending on the handling conditions. When making a decision to adopt our products, please obtain detailed documentations of the products from us.
4. As a principle, we can not provide compensation for any damages to the customer's equipment or device caused by the breakdown or malfunction of our products.
5. Our products are electronics components. Repair or replacement is not supported except some of the products.
6. We do not accept any returns or exchanges for the product. Please carefully check the specifications of the product before placing an order.

Technical Data

7. The content of this website is subject to change without notice for the sake of improvement.

8. Please contact the sales department if you have any questions or concerns.

About This Web Catalog

The information in this web catalog is subject to change without prior notice.